

NOTICE TO INSTALLER: Instructions must remain with installation.
Your Peace of Mind is Our Top Priority®

FM2541
 0415
 Supersedes
 0410

Product information presented here reflects conditions at time of publication. Consult factory regarding discrepancies or inconsistencies.



PUMP COMPANY

Zoeller Family of Water Solutions™

MAIL TO: P.O. BOX 16347 • Louisville, KY 40256-0347
SHIP TO: 3649 Cane Run Road • Louisville, KY 40211-1961
 (502) 778-2731 • 1 (800) 928-PUMP • FAX (502) 774-3624

visit our web site:
www.zoeller.com

Register your
 Zoeller Pump Company
 Product on our website:
<http://reg.zoellerpumps.com/>

**Potable Water Two Stage
 End Suction Centrifugal Pumps**

OWNER'S MANUAL



Congratulations on the purchase of the Zoeller Potable Water Two Stage End Suction Centrifugal Pump. For over sixty years the name Zoeller has represented the standard for submersible sump and sewage pumps. The same high quality workmanship and easy maintenance design has been incorporated into this line of potable water products. This Zoeller system will provide years of trouble-free service when installed according to the manufacturer recommendations.

This manual incorporates the installation, operation, maintenance, and service instructions into one document to aid in the ownership of a Zoeller potable water product. Please read and review this manual before installing the product. Many items contained within, when followed correctly, will not only ensure a long and problem-free life for the system, but also save time and money during installation. Should further assistance be necessary please call our Technical Service department at 1-800-928-PUMP.

Table of Contents	
Safety Instructions.....	1
Limited Warranty.....	2
Preinstallation Information.....	2
Typical Installations	3
Installation Procedures	4-5
Maintenance.....	6
Troubleshooting	7
Dimensions & Repair Parts	8

Owner's Information

Model Number: _____ Date Code: _____

Job Name: _____

Dealer: _____

Date of Purchase: _____

Contractor: _____

Date of Installation: _____

System Readings During Operation: Voltage _____ Amps _____

Safety Instructions

TO AVOID SERIOUS OR FATAL PERSONAL INJURY OR MAJOR PROPERTY DAMAGE, READ AND FOLLOW ALL SAFETY INSTRUCTIONS IN MANUAL AND ON PUMP.

THIS MANUAL IS INTENDED TO ASSIST IN THE INSTALLATION AND OPERATION OF THIS UNIT AND MUST BE KEPT WITH THE PUMP.

 This is a **SAFETY ALERT SYMBOL**. When you see this symbol on the pump or in the manual, look for one of the following signal words and be alert to the potential for personal injury or property damage.

▲ DANGER Warns of hazards that **WILL** cause serious personal injury, death or major property damage.

▲ WARNING Warns of hazards that **CAN** cause serious personal injury, death or major property damage.

▲ CAUTION Warns of hazards that **CAN** cause personal injury or property damage.

▲ NOTICE Indicates special instructions which are very important and must be followed.

THOROUGHLY REVIEW ALL INSTRUCTIONS AND WARNINGS PRIOR TO PERFORMING ANY WORK ON THIS PUMP.

MAINTAIN ALL SAFETY DECALS.

LIMITED WARRANTY

Manufacturer warrants, to the purchaser and subsequent owner during the warranty period, every new product to be free from defects in material and workmanship under normal use and service, when properly used and maintained, for a period of one year from date of purchase by the end user, or 18 months from date of original manufacture of the product, whichever comes first. Parts that fail within the warranty period, one year from date of purchase by the end user, or 18 months from the date of original manufacture of the product, whichever comes first, that inspections determine to be defective in material or workmanship, will be repaired, replaced or remanufactured at Manufacturer's option, provided however, that by so doing we will not be obligated to replace an entire assembly, the entire mechanism or the complete unit. No allowance will be made for shipping charges, damages, labor or other charges that may occur due to product failure, repair or replacement.

This warranty does not apply to and there shall be no warranty for any material or product that has been disassembled without prior approval of Manufacturer, subjected to misuse, misapplication, neglect, alteration, accident or act of God; that has not been installed, operated or maintained in accordance with Manufacturer's installation instructions; that has been exposed to outside substances including but not limited to the following: sand, gravel, cement, mud, tar, hydrocarbons, hydrocarbon derivatives (oil, gasoline, solvents, etc.), or other abrasive or corrosive substances, wash towels or feminine sanitary products, etc. in all applications other than in raw sewage

pumping applications. The warranty set out in the paragraph above is in lieu of all other warranties expressed or implied; and we do not authorize any representative or other person to assume for us any other liability in connection with our products.











Contact Manufacturer at, 3649 Cane Run Road, Louisville, Kentucky 40211, Attention: Customer Service Department to obtain any needed repair or replacement of part(s) or additional information pertaining to our warranty.

MANUFACTURER EXPRESSLY DISCLAIMS LIABILITY FOR SPECIAL, CONSEQUENTIAL OR INCIDENTAL DAMAGES OR BREACH OF EXPRESSED OR IMPLIED WARRANTY; AND ANY IMPLIED WARRANTY OF FITNESS FOR A PARTICULAR PURPOSE AND OF MERCHANTABILITY SHALL BE LIMITED TO THE DURATION OF THE EXPRESSED WARRANTY.

Some states do not allow limitations on the duration of an implied warranty, so the above limitation may not apply to you. Some states do not allow the exclusion or limitation of incidental or consequential damages, so the above limitation or exclusion may not apply to you.

This warranty gives you specific legal rights and you may also have other rights which vary from state to state.

PREINSTALLATION INFORMATION

- 1. Inspect your unit.** Occasionally, products are damaged during shipment. If the unit is damaged, contact your dealer before using.
- 2. Carefully read the literature** provided to familiarize yourself with specific details regarding installation and use. These materials should be retained for future reference.
- 3.**  **▲ WARNING** **“Risk of electrical shock”** Do not remove power supply cord and strain relief or connect conduit directly to the pump. Installation and checking of electrical circuits and hardware should be performed by a qualified and licensed electrician.
- 4.**  **▲ WARNING** Do not lift, carry or hang pump by the electrical cables. Damage to the electrical cables can cause shock, burns or death.
- 5.**  **▲ WARNING** **For your protection, make certain the pump ground wire is properly connected to the ground wire with the incoming power line.** Test for ground at the junction box using an Underwriters Laboratory listed circuit analyzer which will indicate if the power, neutral and ground wires are correctly connected. If in doubt, call a qualified licensed electrician.
- 6.**  **▲ WARNING** Make certain that the receptacle is within the reach of the pump's power supply cord. **DO NOT USE AN EXTENSION CORD.** Extension cords that are too long or too light do not deliver sufficient voltage to the pump motor. But, more important, they could present a safety hazard if the insulation were to become damaged or the connection end were to get wet.
- 7.**  **▲ WARNING** **Make sure the pump electrical supply circuit is equipped with fuses or circuit breakers of proper capacity.** A separate branch circuit is recommended, and sized according to the “National Electrical Code” for the current shown on the pump nameplate.
- 8.**  **▲ WARNING** Pump is designed to pump cold ground water that is free of air or gases. Decreased pump performance and life expectancy can occur if the ground water is not cold (86°F/30°C) or contains air or gases.
- 9.**  **▲ WARNING** **DO NOT** run the pump dry. **DO NOT** run the pump with a completely closed discharge. **DO NOT** pump chemical or corrosive liquids. Failure to follow above warnings could result in damage to the pump, voiding the warranty and causing personal injury.
- 10.**  **▲ CAUTION** Check to be sure your power source is capable of handling the voltage requirements of the motor, as indicated on the pump nameplate.
- 11.** The installation of pumps using auxiliary variable level float switches is the responsibility of the installing party. Care should be taken such that the tethered float switch will not hang up and are secured so that the pump will turn on and off properly.
- 12.**  **▲ CAUTION** Water hammer creates momentary high pressure surges. These surges can cause severe damage to check valves and the piping system. Consideration for water hammer must be included in the piping system design. Reference ASPE Data Book, Chapter 2.33. Some systems may require external spring or lever weighted check valves or other engineered solutions.
- 13.**  **▲ CAUTION** In cold climates the discharge pipe may be subject to freezing. If the riser on the septic tank is above the frost line, it will be necessary to protect the system from freeze up. The discharge pipe can be insulated or the check valve can be removed. If the check valve is removed, the “on-off” cycle must be adjusted for any back-flow from the discharge line.
- 14.**  **▲ WARNING** According to the state of California (Prop 65), this product contains chemicals known to the state of California to cause cancer and birth defects or other reproductive harm.

TYPICAL INSTALLATIONS

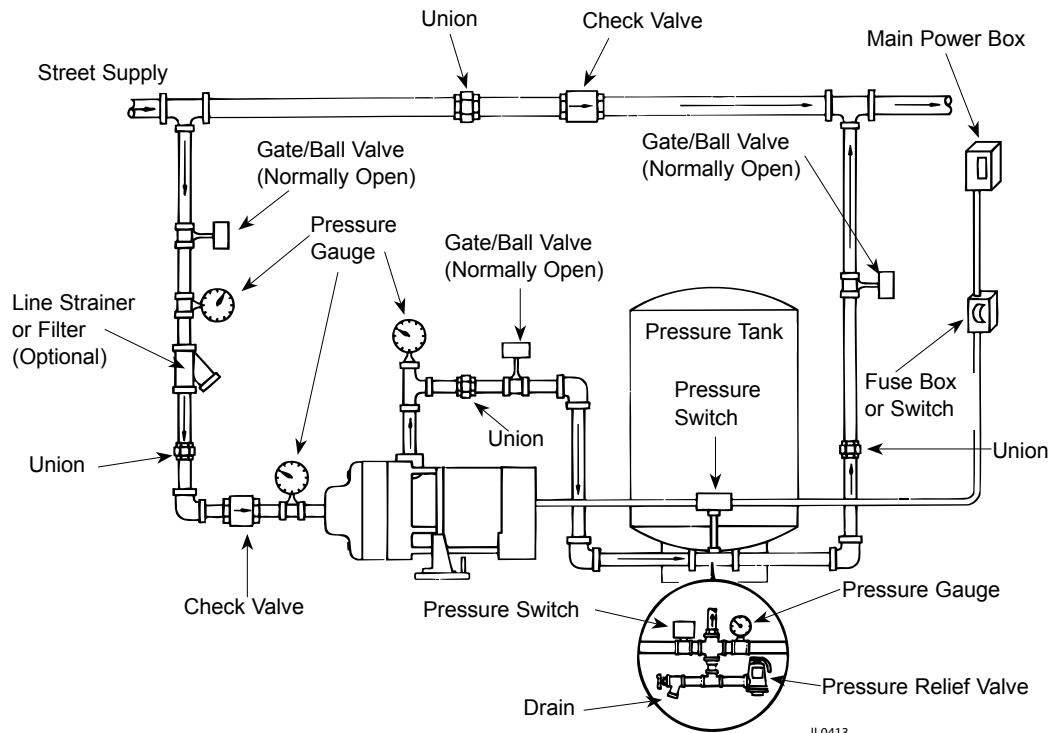

Figure 1

IL0413

To size pressure tank properly, match the drawdown of the tank to the capacity of the pump.

(*) For manual operation, omit the pressure tank and pressure switch. Wire motor direct to fuse box.

⚠ WARNING Install a pressure relief valve on any installation where pump pressure can exceed the pressure tank's maximum working pressure or on systems where the discharge line can be shut off or obstructed. Extreme over pressure can result in personal injury or property damage.

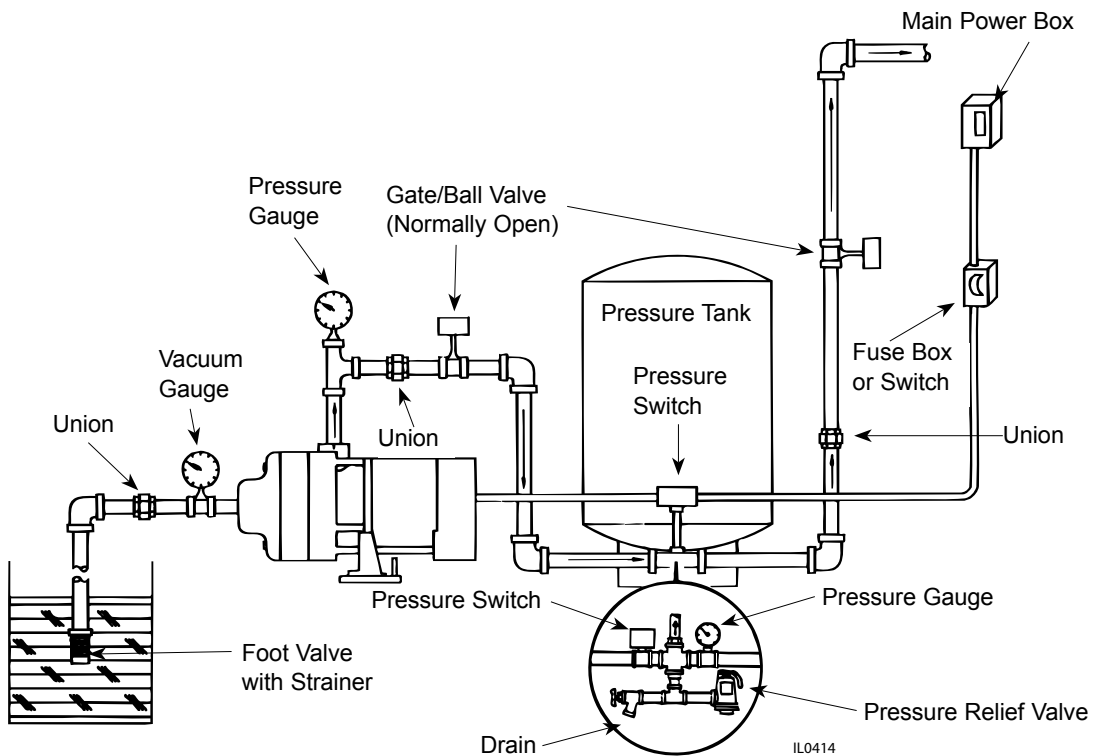

Figure 2

IL0414

READ THESE INSTRUCTIONS CAREFULLY BEFORE INSTALLATION

INSPECTION AND STORAGE

When unpacking the unit, inspect carefully for any damage that may have occurred during shipment. If the unit is received sometime before it can be used, it should be inspected, resealed and stored in a dry location.

LOCATION

IMPORTANT: In installations where property damage might result from an inoperative or leaking pump due to power outages, discharge line blockage or any other reason, a back-up system (s) and/or warning system (s) should be used. Install a gate valve and union in the suction and discharge lines. For removal of the pump for service, close the gate valve and disconnect the union.

1. Locate pump as close to the fluid source as possible.
2. Place unit where the motor electrical components and piping are protected from the weather and extremes of heat, humidity and below freezing temperatures.
3. Mount unit in a dry location that is easily accessible for inspection and maintenance. If a dry location is not available, mount it on a foundation well above the wet floor.
4. Allow ample clearance around unit for free air circulation.

SUCTION LIMITATIONS

1. Units are non self-priming. Normally after being primed the total suction lift of the pump is 25 feet. Suction lift varies depending upon elevation (altitude) and water temperature. See Practical Suction Lift chart.
2. Where liquids at or near their boiling points are being handled, the supply must be located above the suction, so that the available NPSH will be greater than that required by the unit.

Practical Suction Lifts at Various Elevations and Water Temperatures in Degrees Fahrenheit

Altitude	60°	80°	100°	120°	140°	160°	180°	200°
Sea Level	-22	-21	-20	-18	-15	-10	-4	+5
2000	-20	-19	-18	-16	-12	-7	-1	+8
4000	-17	-16	-15	-13	-10	-4	+2	+12
6000	-15	-14	-13	-11	-7	-2	+6	+16
8000	-13	-12	-10	-8	-4	+2	+9	—
10000	-10	-9	-8	-6	-2	+4	+13	—

This table gives the maximum permissible suction lift or the minimum head permitted on the suction side of a pump at various altitudes and liquid temperatures. A minus sign before a number indicates suction lift. A plus sign before a number indicates minimum head. These figures are to be used as a guide.

PIPING

1. Use galvanized piping, rigid plastic or other suitable pipe that will not collapse under suction or rupture due to pressure.
2. The diameter of the suction and discharge pipe should be no smaller than the corresponding tapings of the pump (see Figure 8). If long runs are encountered larger pipe should be used. Smaller pipe will reduce the capacity of the pump.
3. All joints and connections should have Teflon tape or pipe sealing compound (male threads only) applied and drawn up tightly.

CAUTION The entire system must be air and water tight for efficient operation.

PUMP INSTALLATION

Refer to Figures 1, and 2 for typical installations. Both the suction and discharge pipe should be supported at a point near the pump to avoid strains being placed on the pump.

1. If the pump is used as part of a permanent installation, secure to a rigid foundation with appropriate fasteners.
2. Locate the pump as close to the water as possible, keeping the suction pipe as short as conditions permit.
3. Avoid dips or pockets in offset piping or air will accumulate at high points which will make priming difficult.
4. The suction pipe should slope upward to the pump inlet. A horizontal suction line must have a gradual rise to the pump.
5. On suction lift installations, a foot valve located in the water or a check valve located as close to the water as possible will reduce priming time of the pump and help maintain prime. A strainer must be used on the suction line to filter out dirt and debris.
6. A priming tee installed in the pump discharge port allows water to be poured into the pump case and suction piping, which is required for priming on suction lift installations.
7. Install a gate valve and union in the suction and discharge lines. For removal of the pump for service, close the gate valve and disconnect the union.

CAUTION Do not use a globe valve or other restricting type of valve at the discharge. This will seriously restrict the capacity of the pump.

8. Pressure Gauges - Properly sized vacuum or pressure gauges can be installed in both the suction and discharge pipe. The gauges will enable observation of the pump's performance as well as detecting cavitation, vapor binding or other unstable operation.

WARNING A pressure relief valve of adequate capacity must be installed on any installation where the pump pressure can exceed the pressure tank's maximum working pressure or on systems where the discharge line can be shut-off or obstructed. Not providing a relief valve can cause extreme over pressure which could result in personal injury and/ property damage.

WIRING

WARNING Use wire size specified in wiring Chart A. If possible, connect pump to a separate branch circuit with no other appliances on it. If wiring diagram on motor model plate differs from diagram shown in figure 3, follow diagram on motor.

All wiring should be performed by a qualified electrician and in accordance with the national and local electric codes.

1. Motor voltages will vary depending upon the motor horsepower and phase. Refer to the motor nameplate and the Motor Data Chart (Chart B) for voltage and electrical data.

WARNING Make certain that the power supply conforms to the electrical specifications of the motor supplied. Failure to do so may cause premature motor failure and will void the warranty.

2. To change voltage, remove the rear access cover, which is held in place with two (2) screws. For proper electrical connection, refer to the connection diagram located on the motor nameplate or Figure 3.

PUMP INSTALLATION

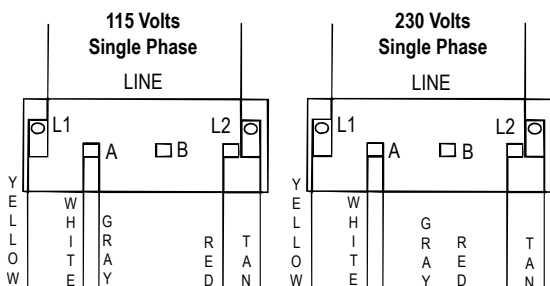

Figure 3.

⚠ WARNING Replace rear

access cover before starting or operating pump. Failure to do so can result in personal injury.

PRIMING

1. Before starting any centrifugal pump, it is absolutely necessary that both the casing and suction pipe be completely filled with liquid. This priming can be accomplished by any of the following methods:
2. When the liquid supply level is above the center line of the pump, it is primed by opening the suction and discharge valves. The inflowing liquid will displace the air and fill the suction line, pump casing, and discharge line up to the level of supply.
3. Where the pump is operating with suction lift and the suction line is equipped with a foot valve, remove the priming plug from the discharge tee (see Figure 2) and fill the pump body and suction pipe completely with water. No additional water will be needed for subsequent start-ups unless the pump body is drained.

Chart A

MINIMUM COPPER WIRE SIZE CHART (GAUGE)

DISTANCE FROM MOTOR TO FUSE BOX METER, OR ELECTRICAL OUTLET	SINGLE PHASE MOTORS												
	1/3 HP		1/2 HP		3/4 HP		1 HP		1-1/2 HP		2 HP		3 HP
	115V	230V	115V	230V	115V	230V	115V	230V	115V	230V	115V	230V	230V
0-50'	14	14	12	14	12	14	10	14	10	12	10	12	10
50-100'	14	14	12	14	12	14	10	14	8	12	8	12	10
100-150'	14	14	12	14	10	14	10	12	6	12	6	12	10
150-200'	12	14	12	14	10	12	8	12	*	10	*	10	10
200-300'	12	14	10	14	8	12	6	10	*	10	*	10	8
Breaker Size (Amps)	15	15	20	15	20	15	30	15	30	20	30	20	30

(*) Not economical to run in 115 volt, use 230 volts

MOTOR PROTECTION

1. All single phase motors have built in thermal protection for all voltages. The overload protects the motor against burnout from overload of low voltage, high voltage and other causes. The device is automatic and resets itself once the temperature has dropped to a safe point. Frequent tripping of the device indicates trouble in the motor or power lines and immediate attention is needed.

⚠ WARNING Never examine, make wiring changes or touch the motor before disconnecting the main electrical supply switch. The thermal device may have opened the electrical circuit.

2. All motors should be equipped with a correctly fused disconnect switch to provide protection. Consult local or national electric codes for proper fuse protection based on motor data chart (see Charts A & B).

4. After the pump is turned on it will require 2-5 minutes before all air is evacuated from the suction line and water begins to flow. If there is no water after 5 minutes, turn the pump off and check the following:
5. Any air leaks on the suction line must be eliminated.
6. Suction pipe inlet should be a minimum of 5 feet below the water level.
7. Total suction lift cannot be greater than 25 feet.
8. Any restrictions in the discharge pipe, such as a closed valve must be eliminated.

NOTE: Unit must be full of liquid before operating. Never run dry, or against a closed discharge. Dry running or running unit against a closed discharge will cause damage to the shaft seal. Do not pump dirty water or abrasive liquids, otherwise the same may occur as if running dry.

MOTOR DATA

Chart B

HP	PH	VOLTS	HZ	RPM	MOTOR VOLTAGE (FACTORY) CONNECT.	SERVICE FACTOR MOTOR AMPS		LOCKED ROTOR AMPS		KVA
						SINGLE PHASE		SINGLE PHASE		
						115V	230V	115V	230V	
3/4	1	115/230	60	3450	115V	14.0	7.0	52.0	26.0	K
1	1	115/230	60	3450	230V	18.0	9.0	70.0	39.0	L
1-1/2	1	115/230	60	3450	230V	21.0	10.5	98.0	49.0	J
2	1	115/230	60	3450	230V	25.0	12.5	116.0	58.0	H

PUMP MAINTENANCE

MOTOR ROTATION

Single phase models are one (1) rotation only (counterclockwise when facing the pump suction tapping) and cannot be reversed.

MAINTENANCE

Lubrication

The pumps and motors require no lubrication. The ball bearings of the motor have been greased at the factory. Under normal operating conditions they should require no further greasing.

Winterizing your Pump

Cracked pump housings caused by freezing are not covered by warranty. To protect your pump from freezing, for best results remove the pump and store in a warm environment. If pump cannot be removed from your system, remove both drain plugs, one on the suction flange and one at the bottom rear of the pump (see Figure 4 below).

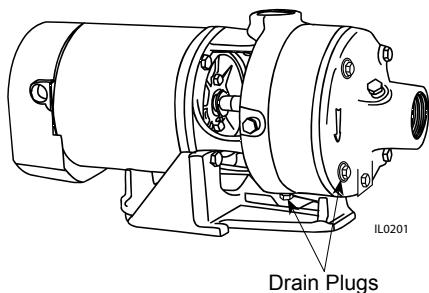

Figure 4 - Drain plug locations.

Allow the water to completely drain from the pump. Re-install both drain plugs and fill pump with RV type antifreeze. Antifreeze also acts as a rust inhibitor. It will help keep rust build up to a minimum and seals lubricated inside the pump while it is not in use.

ROTARY SEAL ASSEMBLY REPLACEMENT

Disassembly

CAUTION When disassembling the pump, care should be taken not to damage the gaskets. If torn or damaged, replace with new gasket (see parts list).

1. Remove the four (4) pump thru bolts that connect the mounting ring to the pump body. Remove the pump body, taking care not to damage the gasket or O-ring.

2. Two Stage End Suction Centrifugal Pumps have two impellers and an intermediate stage. Using an 11/16" open end wrench on the motor shaft extension flat, remove the first impeller by turning or counterclockwise. Remove the intermediate stage taking care not to damage the gasket (gaskets) and unthread the remaining impeller.
3. Remove the mechanical seal assembly. The rotary portion of the seal assembly (carbon ring, Buna-N gasket and spring) will easily slide off the end of the shaft. The ceramic portion can be pried out of the rubber seating using two (2) screwdrivers (see Figure 5).

Reassembly

CAUTION The precision lapped faces of the mechanical seal are easily damaged. Handle the replacement seal carefully. Short seal life will result if seal faces (ceramic & carbon) are nicked, scratched or dirty.

1. Clean the seal cavity of the mounting ring and the motor shaft thoroughly.
2. Apply liquid soap (one drop only) to the outside of the Buna-N gasket that houses the ceramic seal seat. With thumb pressure, press the ceramic seat, polished face up, squarely into the seal cavity (see Figure 6).
3. If seal does not seat squarely, remove and reclean the seal cavity. Place a cardboard washer over the polished seal face and carefully press into place using a piece of pipe or tubing (see Figure 7). Discard cardboard washer.
4. Apply liquid soap (one drop only) to the inside diameter of the rubber drive ring. Slip rubber drive ring (carbon face down) and the spring over the shaft.
5. Reassemble the pump by following the reverse order of the disassembly instructions.

MOTOR REPLACEMENT

1. Nema J motors can be replaced in the field with any standard Nema J jet pump motor by referring to the following instructions and the attached parts list.
2. Follow steps as outlined under Rotary Seal Replacement to remove the pump body, diffuser, impeller and rotary seal.

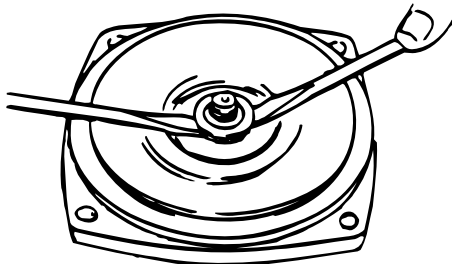

Figure 5 - Remove mechanical seal.

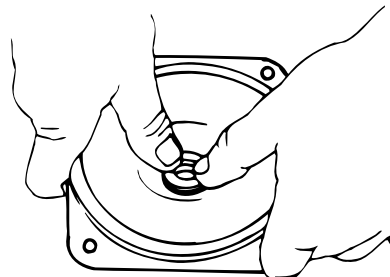

Figure 6 - Press in seal.

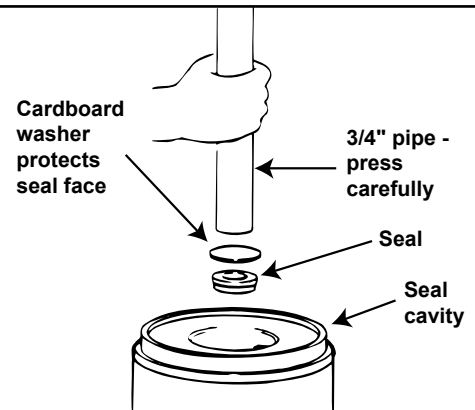

Figure 7 - If necessary, press with cardboard and pipe.

PUMP MAINTENANCE (continued)

- | | |
|--|--|
| <p>3. Remove bolts that connect the motor to the mounting ring and pull motor away.</p> <p>4. Replace motor with standard Nema J jet pump motor by positioning motor against the mounting frame and assembling with four (4) 3/8" x 3/4" cap screws. The mounting base is connected at the bottom of the mounting frame with two (2) 3/8" x 1/2" cap screws.</p> | <p>5. Follow steps of Rotary Seal Assembly to reassemble the remainder of the pump.</p> <p>BECAUSE DAMAGE TO THE SHAFT SEAL IS MOST LIKELY TO OCCUR IN DISASSEMBLY, A NEW SEAL WILL BE NECESSARY.</p> |
|--|--|

TROUBLESHOOTING CHART

SYMPTOM	POSSIBLE CAUSE(S)	CORRECTIVE ACTION
Little or no discharge	<ol style="list-style-type: none"> 1. Pump not primed 2. Total head too high 3. Suction head higher than pump designed for 4. Impeller clogged 5. Incorrect rotation 6. Leak in suction line 7. Inadequate foot valve 8. Impeller damaged 9. Foot valve or suction line not submerged deep enough in water 10. Insufficient inlet pressure or suction head 11. Wrong size piping 12. Casing gasket leaking 13. Suction or discharge line valves closed 	<ol style="list-style-type: none"> 1. Prime unit 2. Shorten suction lift and/or discharge head 3. Lower pump inlet 4. Clean 5. Refer to wiring information 6. Repair or replace 7. Make needed adjustments 8. Replace 9. Submerge lower in water 10. Increase inlet pressure by adding more fluid to fluid source 11. Make needed adjustments 12. Replace gasket 13. Open
Loss of suction	<ol style="list-style-type: none"> 1. Air leak in suction line 2. Suction head too high 3. Insufficient inlet pressure or suction head 4. Clogged foot valve or strainer 	<ol style="list-style-type: none"> 1. Repair 2. Lower pump inlet 3. Increase inlet pressure by adding more fluid to fluid source 4. Clean or replace
Pump vibrates and/or makes excessive noise	<ol style="list-style-type: none"> 1. Mounting plate or foundation not rigid enough 2. Foreign material in pump 3. Damaged impeller 4. Cavitation present 5. Worn motor bearings 6. Bent impeller shaft 	<ol style="list-style-type: none"> 1. Reinforce 2. Clean 3. Replace 4. Check suction line for proper size and be certain valve is open. Remove excessive loops in suction line 5. Replace 6. Replace
Pump will not start or run	<ol style="list-style-type: none"> 1. Improperly wired 2. Blown fuse or open circuit breaker 3. Loose or broken wiring 4. Impeller clogged 5. Motor shorted out 	<ol style="list-style-type: none"> 1. Refer to wiring diagram 2. Replace fuse or close circuit breaker 3. Tighten connections and replace broken wiring 4. Clean 5. Replace
Pumps leaks at shaft	<ol style="list-style-type: none"> 1. Worn mechanical seal 2. Bent impeller shaft 	<ol style="list-style-type: none"> 1. Replace 2. Replace

DIMENSIONAL DATA

Chart C Two Stage End Suction Centrifugal Pump Dimensions									
HP	A	B	C	D	E	F	G	H	J
3/4	4	4-5/8	7-9/16	4-13/16	8-3/4	6-1/4	7	8-1/8	17-7/8
1	4	4-5/8	7-9/16	4-13/16	8-3/4	6-1/4	7	8-1/8	18-3/8
1-1/2	4	4-5/8	7-9/16	4-13/16	8-3/4	6-1/4	7	8-1/8	19
2	4	4-5/8	7-9/16	4-13/16	8-3/4	6-1/4	7	8-1/8	19-1/2

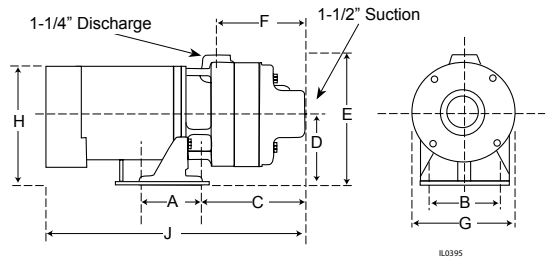

Figure 8 - Two stage End Suction Centrifugal Pump.

REPAIR PARTS

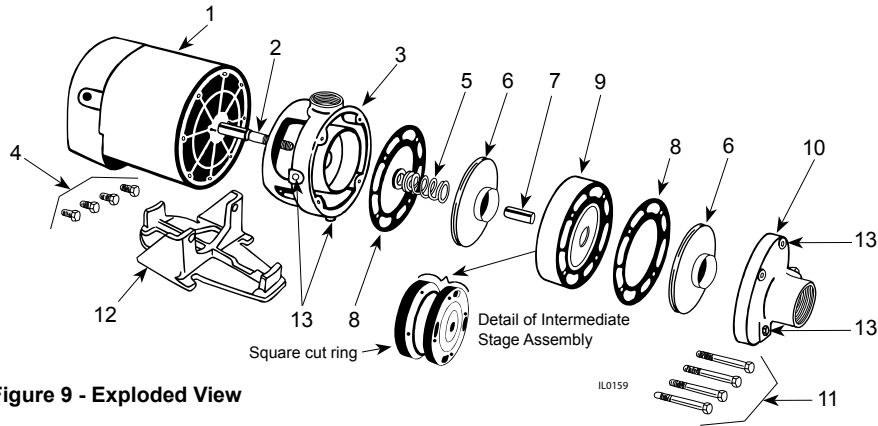

Figure 9 - Exploded View

TWO STAGE END SUCTION CENTRIFUGAL PUMP REPAIR PARTS		MODEL	NE306	NE307	NE308	NE309
		HP	3/4	1	1-1/2	2
		STAGES	2	2	2	2
ITEM	DESCRIPTION	PART NO.	QUANTITY			
1	Motor, Nema J - 1 Ph Motor Cover w/Screws Screws, Cover	98J107	98J110	98J115	98J120	
		021301R	1	1	1	1
		021302	2	2	2	2
‡	Slinger Washer	126905	1	1	1	1
2	Shaft		135279A	135279A	135279A	135279A
3	Mounting Ring	125204	1	1	1	1
4	Hex Hd. Cap Screws 3/8" x 3/4"	*	2	2	2	2
5	Seal, Rotary w/Spring	131100	1	1	1	1
6	Impeller, Thermoplastic		† 133425	† 133427	† 139180	† 128472
7	Spacer, Shaft	133380	1	1	1	1
8	Gasket	130968	2	2	2	2
9	Intermediate Stage Assembly**	023405	1	1	1	1
‡	Suction Clearance Ring	130957	1	1	1	1
‡	Hub Clearance Ring	131282	1	1	1	1
‡	Square Cut Ring Intern. Stg.	020240	1	1	1	1
10	Suction Flange Assembly	023404	1	1	1	1
‡	Suction Clearance Ring	130957	1	1	1	1
‡	Suction Bearing	020053	1	1	1	1
11	Pump thru Bolts 3/8" x 3-1/4"	*	4	4	4	4
12	Base w/Bolts 3/8" x 1-1/4"	020054	1	1	1	1
13	1/4" NPT Plug	*	4	4	4	4

(*) Standard hardware item.
 (†) For quantity required - See number of stages.
 (‡) Not shown.
 (**) Includes two castings, square cut ring, suction and hub clearance ring - See detail drawing.