

Product information presented here reflects conditions at time of publication. Consult factory regarding discrepancies or inconsistencies.



MAIL TO: P.O. BOX 16347 • Louisville, KY 40256-0347
 SHIP TO: 3649 Cane Run Road • Louisville, KY 40211-1961
 TEL: (502) 778-2731 • 1 (800) 928-PUMP • FAX: (502) 774-3624

Visit our web site:
zoellerpumps.com



MODELS 818 - 819 - 820 GRINDER PUMPS SPECIFICATIONS SHEET 1.0, 1.5 & 2.0 HP



APPLICATIONS

- Sanitary Sewage
- Housing Developments
- Pressure Sewers

SPECIFICATIONS

PUMP:

- Automatic with integral on-off switch.
- Discharge Size - 1-1/4" NPT vertical.
- Mechanical Seal - carbon/stationary, ceramic/rotary, with Buna-N elastomers.
- Construction - Cast Iron ASTM A-48, Class 30, 30,000# tensile strength.
- Corrosion resistant powder coated epoxy finish.
- 440C Stainless Steel cutter and plate hardened to Rockwell C 55-60.
- Attaching Hardware and Lifting Handle - 304 stainless steel.
- Square-Ring Seal - Neoprene.
- Impeller - Engineered, glass-filled plastic with SS insert and top pump out vanes.

- OPTIONAL:**
- Nonautomatic configuration
 - Rail systems
 - Additional cord length ___ ft.
 - QLS Series pre-fabricated lift station

MOTOR:

- 2 HP, 3450 RPM.
- Capacitor Start/Run 1 Ph Motor with internal starting circuit.
 200 & 230 Volt : 1.0, 1.5 & 2.0 HP
 115 Volt: 1.0 HP
- 3 Ph induction motor - 200/230/460/575 Volt
- 416 Stainless Steel Motor shaft.
- Stator - Class B insulation and lead wires.
 Nema B design.
- Integral Thermal Overload, single phase units
- Housing - Cast Iron, oil-filled, protected by cooling fins.
- Upper & Lower Ball Bearings - Dual high carbon chromium steel.
- Power Cable Length - 20'

DIMENSIONS:

Height: 18-5/8"
 Major Width: 11-5/8"
 Weight: 91 lbs.



Tested to UL778 and
 cCSAus 22.2 108
 Standards.

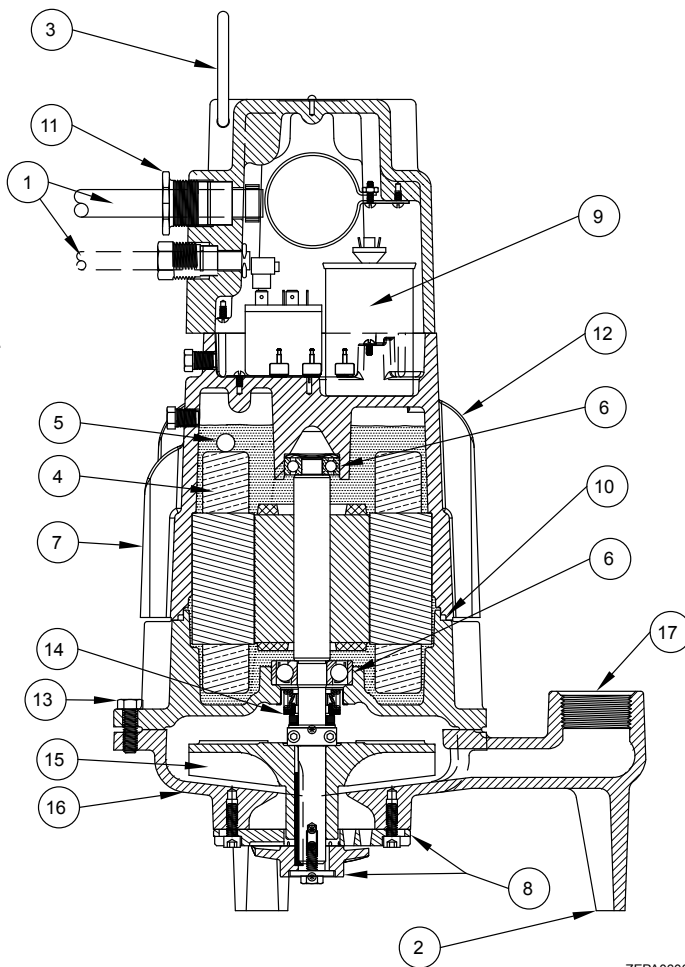

ZEPA0600B

FEATURES

EASY INSTALLATION: Pump is normally supplied with twenty foot of multi conductor, power cable (1) as standard, with automatic units furnished with an integral on/off mechanical float switch. Alternate cable lengths are available. Units have 3 legs (2) as an integral part of pump housing for free standing requirements. Pump and motor assembly can be easily lowered into position, without disturbing the piping, by use of a rail system. Pump is furnished with a stainless steel lifting handle (3).

Long lasting internal components - Class B insulation system (4) rated for 130°F (54°C) max. liquids. Thermal protection (5) standard on all motors. Conservatively rated antifriction ball bearings (6) for thrust loads. Finned, oil filled motor housing (7) for greater heat dissipation, and cooler running motors. Cutter and plate (8) can be resharpened to extend pump life. Both are made of high quality 440C stainless steel and hardened to a value of 55-60

on a Rockwell C scale. Capacitor Start/Capacitor Run single phase motor (9) provides extra start and run torque for cutting.

Complete environmental protection - Neoprene square ring (10) and heavy duty cord connectors (11) keep liquid from entering the motor assembly. Motor housing is constructed of finned powder coated epoxy Class 30 cast iron (12). Hardware (13) is stainless steel. Seal faces (14) are carbon and ceramic for corrosion resistance and provide complete protection for motor internals. Seal has stainless steel and Buna-N components. Vent hole helps prevent air locking. Engineered plastic vortex impeller (15) with top pump out vanes for seal protection is keyed and bolted to the shaft. The pump housing (16) has a concentric design thereby equalizing the pressure forces inside the housing, which will extend the service life of the seal and bearings. All pumps come with 1-1/4" NPT female vertical discharge (17).

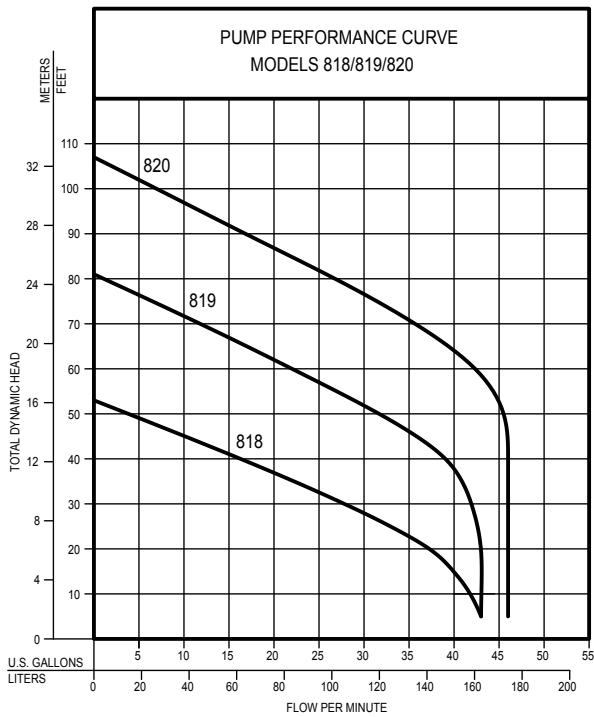

154108

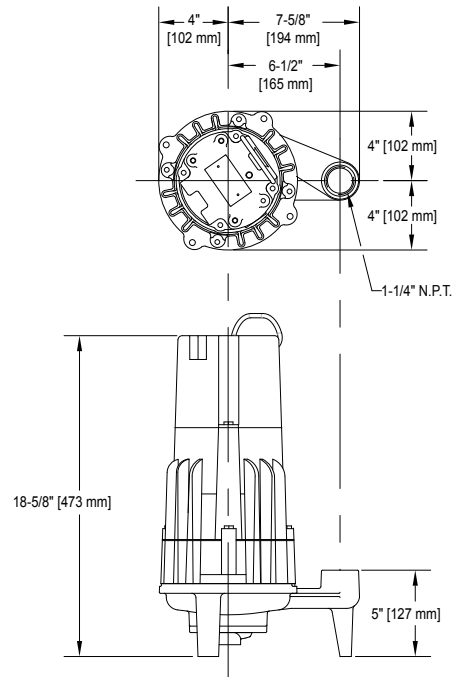

SK1621

ALARM AND CONTROL PANELS

For use with 1 Ph automatic units



Model 10-0623



Tested to UL Standard UL 508
& Certified to CSA Standard
C22.2 No. 205

- Audible & visible high water alarm
- Alarm test & silence switch
- Float switch
- For indoor or outdoor installation

CONTROL PANELS

For use with nonautomatic units



Tested to UL
Standard UL508

SIMPLEX PANELS:

- P/N 10-4465 1 Ph, 7.0-15.0 Amps
- P/N 10-1078 3 Ph, 2.5-4.0 Amps, 200-460 V
- P/N 10-1080 3 Ph, 4.0-6.3 Amps, 200-460 V
- P/N 10-1082 3 Ph, 6.0-10.0 Amps, 200-460 V
- P/N 10-1083 3 Ph, 9.0-14.0 Amps, 200-460 V
- P/N 10-1132 3 Ph, 1.6-2.5 Amps, 575 V
- P/N 10-1134 3 Ph, 2.5-4.0 Amps, 575 V
- P/N 10-1136 3 Ph, 4.0-6.3 Amps, 575 V

DUPLEX PANELS:

- P/N 10-4464 1 Ph, 7.0-15.0 Amps
- P/N 10-1106 3 Ph, 2.5-4.0 Amps, 200-460 V
- P/N 10-1108 3 Ph, 4.0-6.3 Amps, 200-460 V
- P/N 10-1110 3 Ph, 6.0-10.0 Amps, 200-460 V
- P/N 10-1111 3 Ph, 9.0-14.0 Amps, 200-460 V
- P/N 10-1154 3 Ph, 1.6-2.5 Amps, 575 V
- P/N 10-1156 3 Ph, 2.5-4.0 Amps, 575 V
- P/N 10-1158 3 Ph, 4.0-6.3 Amps, 575 V

- NEMA 4X
- Simplex and Duplex
- Motor contactor
- Circuit breaker
- H-O-A switch
- Audible & visible high water alarm w/ dry contact



MAIL TO: P.O. BOX 16347 • Louisville, KY 40256-0347
SHIP TO: 3649 Cane Run Road • Louisville, KY 40211-1961
(502) 778-2731 • 1 (800) 928-PUMP • FAX (502) 774-3624

Trusted. Tested. Tough.™

Visit our web site:
zoellerpumps.com